

Item No	Item Title	Item Description	Item Quantity	Unit of Measure	Consignee ID	Delivery Period (In number of days)
1	1.01	SAP ITEMCODE : 1300000956 DEE SHACKLE - HOT DEEP GALVANIZED DEE SHACKLE WITH SCREW PIN OF CAPACITY 6.5 TONNE WITH IDLR CERTIFICATE, DIA. OF PIN - 25, DIA OF BODY (TRADE SIZE) - 22 + 1 MM INNER WIDTH - 38 MM +- 1 MM, INNER LENGTH - 72 MM +- 1 MM Outer Dia - 52 +- 1 MM KINDLY REFER DRAWING FOR FURTHER REFERENCE	100	NOS.	MRARKHAN	30

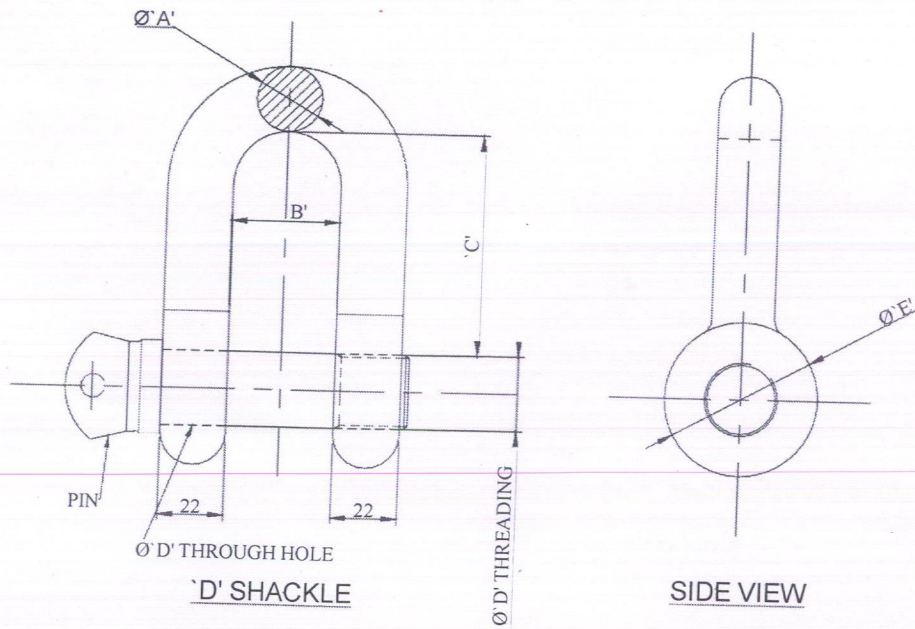

DIMENSIONS TABLE	
DIMENSION	MEASUREMENT IN MILIMETER
'ØA'	22 +1
'B'	38 ±1
'C'	72 ±1
Ø'D'	25
Ø'E'	52 ±1



MUMBAI PORT AUTHORITY
MECHL. & ELECT. ENGG. DEPARTMENT

SUBJECT: MOT JAWAHAR DWEEP

TITLE:
'D' SHACKEL & PIN FOR FENDERAT JAWAHAR DWEEP
DRAWN:S.V.LONDHE DATE:06-06-2024 SCALE: N.T.S
PREPARE BY:Mr.T.BHOGALE CHECKED BY :Mr.C.NIRMAL

APPROVED BY:

DRG.NO.

Mr. ANJAN KUMAR MAITI
Dy. CHIEF MECHANICAL ENGINEER

BIM-128/A

NOTE-
ALL DIMENSIONS ARE IN MM

IDLR Certificate